

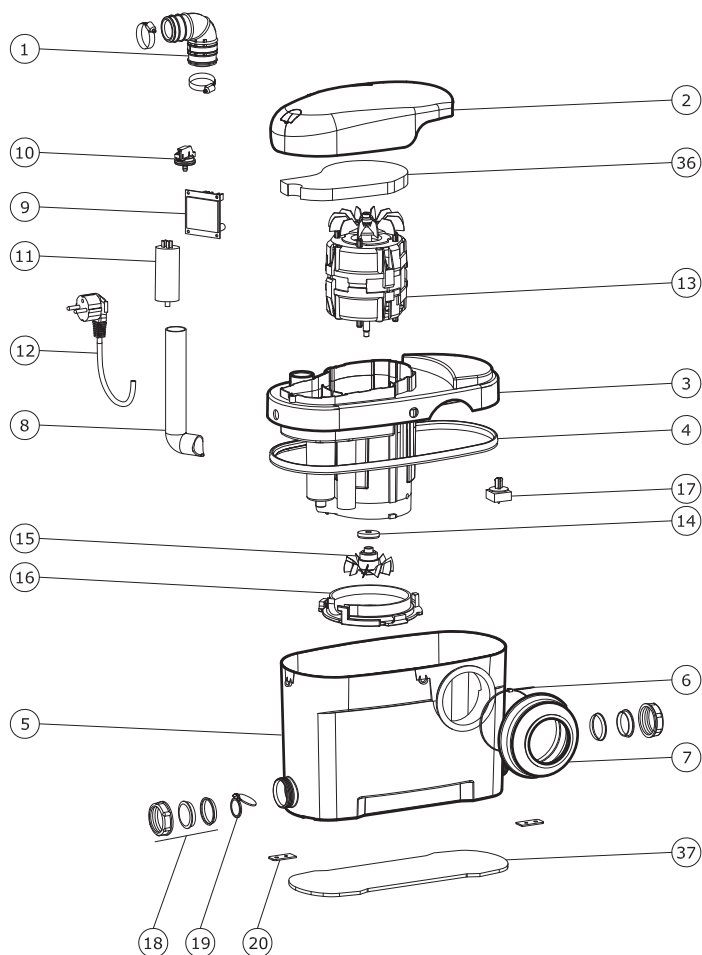

CÔTÉ PRO

DONNÉES TECHNIQUES

► VUE ÉCLATÉE DU PRODUIT



- 1 EVACUATION CLAPET ANTI RETOUR
- 2 CAPOT
- 3 CUVE INTERNE
- 4 JOINT INTERCUVE
- 5 CUVE EXTERNE
- 6 COLLIER OU VIROLLE
- 7 MANCHETTE RACCORD CUVETTE
- 8 COUDE INTERNE EVACUATION
- 9 CARTE ELECTRONIQUE
- 10 PRESSOSTAT
- 11 CONDENSATEUR
- 12 PRISE ELECTRIQUE
- 13 MOTEUR NU
- 14 BAGUE CYCLAM
- 15 RAPE + BAGUE CYCLAM TOURNANTE
- 16 VIROLE DE BROYAGE
- 17 CLAPET EVENT
- 18 BOUCHON ENTREE LATERALE
- 19 CLAPET INTERNE LATERAL
- 20 PATTE DE FIXATION
- 36 MOUSSE CAPOT
- 37 MOUSSE SOL

► SCHÉMA TECHNIQUE

► PERFORMANCES

